

Right Angle Gear Drives for Cooling Towers



Amarillo Gear Company

Global

FAN DRIVE



Amarillo Gear
安马里罗齿轮（江苏）有限公司



Global Fan Drives for Cooling Towers

Amarillo Gear has long been recognized for providing reliable fan drives that are specifically designed for the harsh operating conditions of evaporative heat transfer equipment. Amarillo's fan drive reliability and longevity occurs because of its commitment to new technologies and focused quality workmanship. From this, the new Global Fan Drive has been developed as an extension to our classic fan drives that will span another range of applications resulting in Amarillo Gear now offering the most complete range of solutions for the heat transfer industry.

Global Fan Drive Features

Design features and ratings are in accordance with, or exceed the minimum requirements of AGMA (American Gear Manufacturers Association).

Housings & Castings

Castings are rigidly designed and constructed to absorb internal and external loads with minimum deflection. Gear case and cover are manufactured to assure permanent alignment of bearings and gears under load. The sloped floor of the gear case adds rigidity and permits complete oil drainage. All casting materials are gray cast iron (ASTM A48, Class 30) for effective dampening of noise and vibration. All mating surfaces are sealed using "formed-in-place" gasket material that eliminates "weeping" associated with fiber-type gaskets. Gear cases are pre-drilled with pilot holes to assist in installation of dowel pins.

Spiral Bevel Gears

Designed and manufactured by Amarillo Gear Company LLC specifically for fan drive service. All spiral bevel gears are precision machined from high grade alloy steel, case carburized and lapped in pairs. All gearing is designed to AGMA 6013-A06.

Helical Gears

Helical gears are designed specifically for fan drive service and are precision machined from high grade alloy steel, case carburized and precision form ground to provide low-noise, low vibration operation.

Bearings

All bearings are designed and sized to ensure industry leading performance and reliability. Sourcing of all bearings is from tier one manufacturers, known around the world for their quality and performance.

Quiet Operation

Quiet operation of the Global Fan Drive is achieved through careful design and controlled manufacturing methods of components. Our engineers understand all of the many parameters that affect gear noise and have applied the latest research to the design and manufacture of all components. Parameters that reduce gear noise are controlled during design, manufacturing and assembly to ensure quiet operation. Rigid shafts and permanently aligned housings guarantee alignment of gears under load. Distances between vertical bearings have been maximized to provide stable operation and reduced vibration. Test results collected in our state-of-the-art test facility, taken under full load and thrust, show that our sound levels are the lowest available in the industry.

Shafting

The Global fan drive features rugged amply sized alloy steel spindles for the fan. Surfaces for gears, bearings, input couplings and fan hub are precision machined.

Shaft Seals

Both the input and output shaft openings have 2 spring-loaded, single-lip seals to keep outside contamination from entering the gearbox. In addition, the output shaft has a labyrinth-type plate directly mounted to the shaft to triple protect the fan drive from contamination penetration due to the natural effect of gravity.

Lubrication

An oversized oil slinger on the input shaft provides excellent lubrication in either direction or at half speed operation. Continuous circulation of oil to all bearings is assured by location of properly sized channels and baffles. Minimum input speeds with the oversized oil slinger can go as low as 450 rpm. The Global Fan Drive can also be supplied with a positive displacement bi-directional mechanical oil pump with all plumbing internal to the fan drive. The pump is driven from the intermediate shaft and provides a redundant lubrication system for extreme reliability and input speeds as low as 100 rpm. Oil level can be visually confirmed by viewing through the oil sight glass.

Thermal Efficiency

The thermal ratings of the Global Fan Drive are equal to or exceed the service ratings listed when the discharge air temperature is 48°C or less. Added thermal cooling performance comes from the specially designed and sized input shaft fan. This fan has been designed specifically for use in a cooling tower application and is engineered to have top performance, even in very low static pressure conditions. Contact the factory for thermal ratings when the air temperature exceeds 48°C.

Service Openings

Large inspection opening facilitates periodic inspections. Ports for oil fill, oil drain and venting are tapped and located for installation of remote service piping when desired.

Optional Features

Anti-windmill backstops, oil level switches, oil heaters/thermostat, oil temperature switches/gauges, vibration transducers, special output shaft dimensions and other accessory items are available on special order.



Use this formula to determine your required ratio.*

Use this formula if your service factor differs from 2.0**

$$\text{Required Ratio} = \frac{\text{Input or Driver Speed}}{\text{Output or Fan Speed}}$$

$$\text{New Service Ratio} = \text{Published Service Rating} * \left(\frac{2.0}{\text{New Service Factor}} \right)$$

KILOWATT RATINGS WITH SERVICE FACTOR = 2.0							
Nominal Ratio	Motor Speed (rpm)	Models					
		G80	G100	G110	G120	G125	G130
7.5	Exact Ratio	7.53	7.50				
	1800	96	135				
	1500	80	112				
	1200	64	90				
8	Exact Ratio	7.97	7.96	8.00			
	1800	95	132	201			
	1500	79	110	168			
	1200	63	88	134			
9	Exact Ratio	8.96	8.96	9.04	9.04		
	1800	91	132	192	315		
	1500	76	110	160	263		
	1200	61	88	128	210		
10	Exact Ratio	9.90	10.19	9.90	9.90		
	1800	90	132	182	303		
	1500	75	110	152	253		
	1200	60	88	121	202		
11	Exact Ratio	11.08	11.05	11.14	11.17	11.18	11.20
	1800	90	115	165	272	285	342
	1500	75	96	137	226	237	285
	1200	60	77	110	181	190	228
12.5	Exact Ratio	12.51	12.50	12.61	12.50	12.27	12.27
	1800	72	108	159	244	261	321
	1500	60	90	132	203	217	268
	1200	48	72	106	162	174	214
13	Exact Ratio	12.93	12.94	12.93	13.05	13.17	13.06
	1800	69	108	144	234	247	315
	1500	58	90	120	195	206	263
	1200	46	72	96	156	165	210
14	Exact Ratio	13.93	14.06	13.93	13.89	13.98	13.83
	1800	65	108	141	222	233	302
	1500	55	90	117	185	194	252
	1200	44	72	94	148	155	201
15	Exact Ratio			15.13	15.00	14.69	15.11
	1800			132	205	222	278
	1500			110	171	185	231
	1200			88	137	148	185
16	Exact Ratio				16.25	15.98	16.17
	1800				190	205	261
	1500				159	171	217
	1200				127	137	174
18	Exact Ratio				18.15	17.88	18.27
	1800				171	181	232
	1500				142	151	193
	1200				114	120	154

*Once the required ratio is determined, always select a gear drive with a service rating that meets or exceeds the power rating of the input driver.

**Contact factory for actual values for your application.

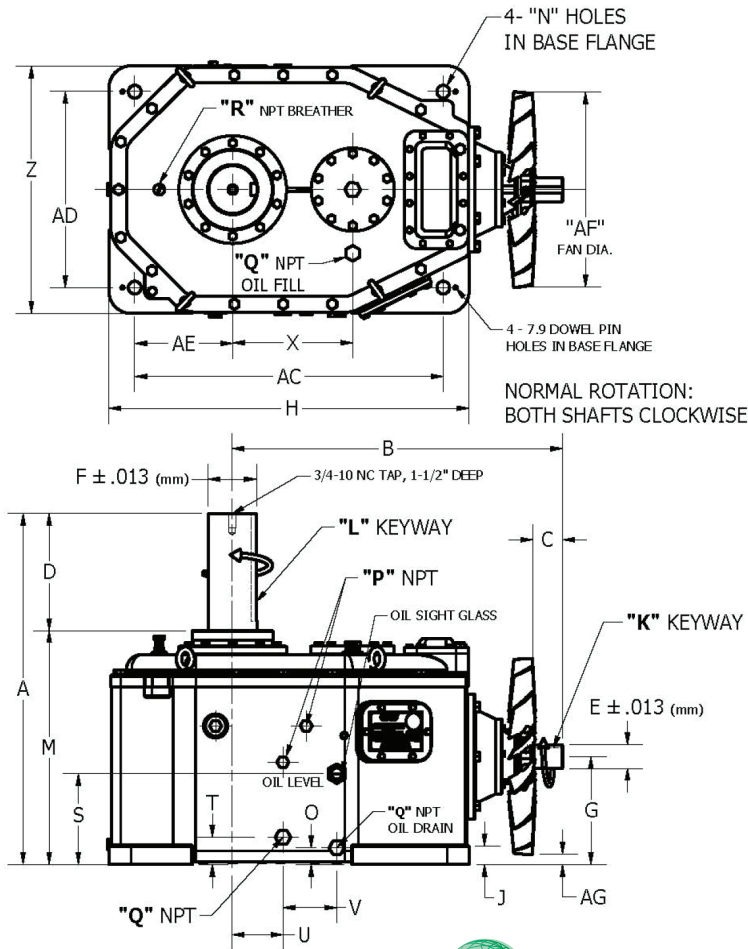

TABLE I - DIMENSIONS (mm)

Model	G80	G100	G110	G120	G125	G130
A	723.9	828.8	873.3	911.4	936.8	968.5
B	736.6	831.9	814.3	898.7	955.8	993.9
C	127.0	127.0	120.7	115.8	146.1	146.1
CN	85.9	85.9	85.9	79.5	98.6	98.6
D	254	305	305	305	305	305
E	47.6	47.6	61.9	61.9	74.6	74.6
F	88.9	101.6	114.3	127.0	127.0	139.7
G	215.9	241.3	260.4	279.4	304.8	304.8
H	641.4	768.4	844.6	933.5	933.5	1038.4
J	47.6	47.6	47.6	47.6	47.6	38.1
M	469.9	524.0	568.5	606.6	632.0	663.7
N	26.9	26.9	33.3	33.3	33.3	33.3
O	54.1	54.1	38.1	42.9	42.9	44.5
S	177.8	177.8	200.2	235.0	260.4	235.0
T	69.9	69.9	69.9	69.9	69.9	82.6
U	38.1	44.5	69.9	130.3	130.3	92.2
V	88.9	101.6	101.6	139.7	139.7	138.2
X	209.6	254.0	279.4	311.2	311.2	349.3
Z	469.9	558.8	596.9	641.4	641.4	743.0
AC	539.8	660.4	743.0	800.1	800.1	886.0
AD	368.3	457.2	495.3	508.0	508.0	590.6
AE	184.2	225.6	263.7	254.0	254.0	295.4
AF	406.4	406.4	508.0	508.0	558.8	558.8
AG	12.7	38.1	6.4	25.4	25.4	25.4
WT (kg.)	380	568	719	912	1039	1184
Thrust (kg.)	1724	2449	2699	4037	4196	4944

TABLE II - DIMENSIONS (in)

Model	K	L	P	Q	R
G80	3/8 x 3/16	7/8 x 7/16	3/4	1	1/2
G100	3/8 x 3/16	1 x 1/2	3/4	1	1/2
G110	5/8 x 5/16	1 x 1/2	3/4	1	1/2
G120	5/8 x 5/16	1 1/4 x 5/8	3/4	1	1/2
G125	3/4 x 3/8	1 1/4 x 5/8	3/4	1	1/2
G130	3/4 x 3/8	1 1/4 x 5/8	3/4	1	1/2

TABLE III - WEIGHTS & SHIPPING DIMENSIONS (mm)

Model	Weight with Export Crate (kg)	Export Crate Dimensions (mm)		
		Length	Width	Height
G80	449	1016	762	1041
G100	676	1245	813	1041
G110	821	1245	813	1041
G120	1002	1270	813	1118
G125	1157	1422	1041	1143
G130	1343	1422	1041	1143

ATTENTION: Drawings and measurements intended for illustration and reference purposes only. Dimensions subject to change. Contact Amarillo Gear Company for documents intended to be used for design.



Amarillo Gear (Jiangsu) Co., Ltd.

No. 3, Workshop on 16 Xingao Rd. Shibang Industry Park, Niutang Town Changzhou, Jiangsu Province, China
 Telephone: (+86) 519-80581688
 Email: info@amarillogearjiangsu.com