



Amarillo[®] Gear
安马里罗齿轮（江苏）有限公司



AMARILLO GEAR (JIANGSU) CO., LTD.

No. 3, Workshop on 16 Xingao Rd.
Shibang Industry Park, Niutang Town
Changzhou, Jiangsu Province 213168 China
T: 0519 80581688 F: 0519 80586006
info@amarillogearjiangsu.com

OPERATION AND MAINTENANCE INSTRUCTIONS FOR AMARILLO COOLING TOWER DRIVES – GLOBAL[®] MODEL

Each Amarillo Global[®] Cooling Tower Drive is the result of careful design and manufacturing techniques. As with any precision machine component, proper installation, maintenance and operating procedures are imperative for long life and trouble free service. The following instructions are offered to cover most conditions. Our engineers will be pleased to assist when unusual conditions require special procedures.

INSTALLATION: Make sure that the gear drive is filled with the proper amount and type of lubricant. Install oil if drive is shipped without oil or add oil if spillage has occurred. The initial oil level should be to the middle of the oil level sight gauge and should be maintained so that the oil level is always visible in the sight gauge window when the unit is stationary, level, and the oil is at ambient temperature.

Remove rust preventive from shaft extension and clean thoroughly. Install coupling halves. Couplings should be machined for a clearance fit. Hammering or mechanically forcing the coupling on the shaft can damage the bearings or disturb the setting of the gears and is not permissible. Interference fits are permissible if the coupling half can be heated for installation and fitted without hammering or mechanically forcing on the gear drive shaft. Check runout of aligning surfaces on both coupling halves before installing connecting members. Clean any excess anti-sieze compound off of the shaft, especially near the oil seals.

Level gear drive. If shimming is required, take precautions to prevent distortion of the housing. Align driver with gear drive to obtain parallel and angular alignment. Recheck alignment after two weeks of operation.

On "Wet Tower" installation, the breather plug located on the top of the gear housing must be removed and piped to the outside of the stack, away from the direct stream of moist air. Installation of piping to the other service openings will expedite routine maintenance and can be installed if desired. Service openings include oil fill and oil drain. Use a suitable sealer for all pipe joints and coat all exposed threads to prevent corrosion. Check all external fasteners for tightness.

OPERATION: No special break-in procedures are necessary, except as noted under lubrication.

Each unit is subjected to a running test at the factory to assure smooth and quiet operation. Excessive noise or vibration at initial operation is an indication of one or a combination of the following: (1) Misalignment (2) Imbalance of fan or other rotating parts (3) Improperly adjusted fan blades (4) Torsional vibration (5) Unstable mounting. If noise or vibration persists, shut the unit down and correct the fault before further operation.

On installations with **two speed motors**, allow a suitable time delay before switching from high speed to low speed. The fan must be at, or below, the low speed before energizing the low speed winding.

When reversing direction of rotation, allow the fan to come to a complete stop before restarting the motor. Standard gear drives may be operated in reverse at half speed (the reversing speed must be greater than 450 rpm) continuously without damaging the gear drive. Contact the factory for recommendations prior to running the gear drive in **reverse at full speed** for extended time.

On installations with **variable speed motors**, do not operate standard gear drives below 450 RPM motor speed. Operation at motor speeds less than 450 RPM require a mechanical oil pump for proper lubrication. The addition of this option allows operation with no minimum speed restrictions.

On most fan drive systems, it is common for one or more resonant speeds to exist between 0 and 1800 RPM. Continued operation at a resonant speed condition will result in torsional vibrations which can be damaging to all components of the system. The most common indicator of torsional vibration is an unusual rumbling or grinding noise from the gear drive at a sharply defined speed. The noise will disappear when the speed is increased or decreased. The noise is not indicative of a defect, but results when the vibratory torque exceeds the drive torque causing the gear teeth to separate and clash together very rapidly. On **variable speed** applications, operation within $\pm 10\%$ of a resonant speed should be avoided and the transition through a resonant speed range should be swift. Contact Amarillo Gear for more information on resonant speeds and torsional vibrations.

MAINTENANCE: Check oil level weekly with each unit stopped. Add oil if level is below oil level indicator.

Daily visual inspections and observation for oil leaks and unusual noises and vibrations are recommended. If any of these occurs, the unit should be shut down and the cause found and corrected.

Periodic checks should be made of the alignment of all components of the system. Also, all external fasteners should be checked for tightness.

Special precautions are necessary during periods of inactivity in excess of one week. When the internal parts are not continually bathed by the lubricant as during operation, the gear drive is particularly vulnerable to attacks by rust and corrosion. For best results, let the drive cool for approximately four hours after shutdown, start the motor and let run for approximately five minutes. This will coat the internal parts of the drive with cool oil. Thereafter, run the fan for five minutes once a week throughout the shutdown period to maintain the oil film on the internal parts of the gear drive.

If the drive is to be inactive for a prolonged period, it is recommended that the unit be completely filled with oil. This can be accomplished by filling through the air breather port. Cover the drive with a tarpaulin or other protective covering. Drain the excess oil before returning the gear drive to service.

By following the above procedures, each Amarillo Global[®] Cooling Tower Drive will provide years of useful service. In the event repairs are necessary, most parts are stocked at the factory and normally can be shipped within twenty-four hours after receipt of an order. Prompt factory re-build service is also available.

DOUBLE REDUCTION

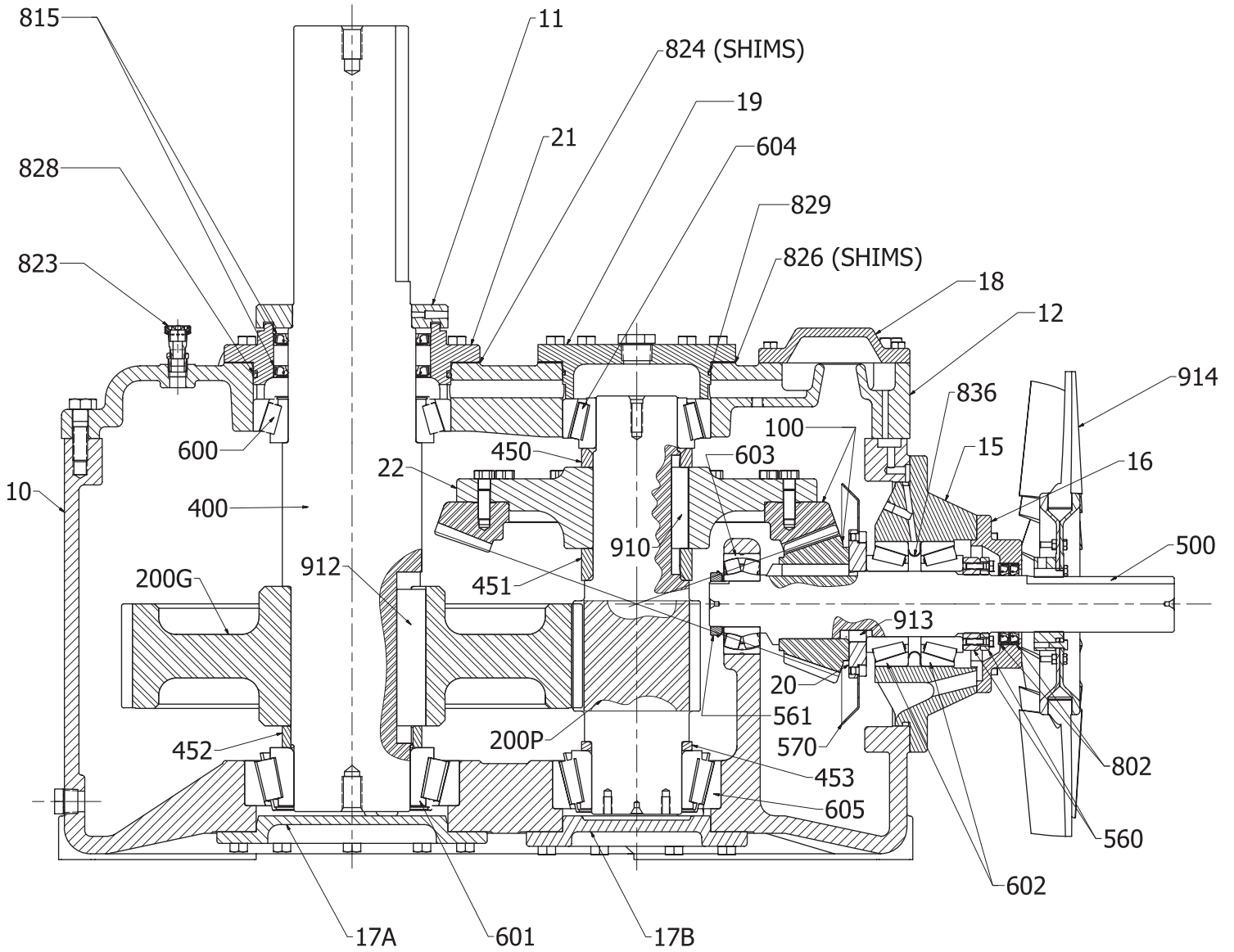

MODELS G110, G120, G125 & G130

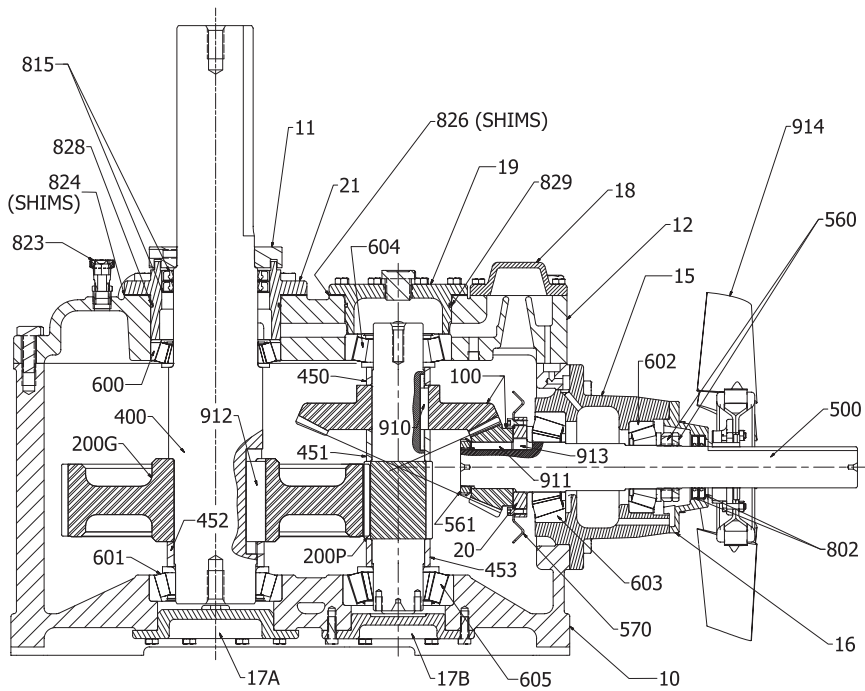

MODELS G80 & G100

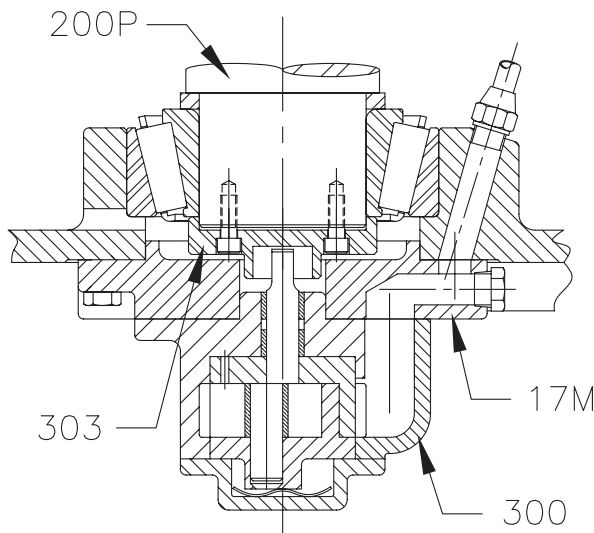

OPTIONAL OIL PUMP

- 1) Specify Serial Number when ordering repair parts.
- 2) Spiral Bevel Gear Sets are specified by Model Number and Ratio.
- 3) A Vertical Gear Mount (Ref. No. 22) is not used on all ratios. If a Vertical Gear Mount is required, then it should be purchased with a Helical Pinion (Ref. No. 200P) and the Vertical Gear Mount assembled on the Helical Pinion at the factory.
- 4) Not applicable to all ratios; consult factory.
- 5) Gear Case and Cover not available for purchase.

REF. NO.	PART NAME
10	
11	Upper Seal Plate
12	
15	Horizontal Carrier (outer)
16	Horizontal seal plate
17A	Lower Brg. Cover (output shaft)
17B	Lower Brg. Cover (Interm. Shaft)
17M	Lower Brg. Cover for Oil Pump
18	Oil Pocket Cover Plate
19	Upper Brg. Cover (Interm. Shaft)
20	Oil Slinger Plate
21	Vertical Seal Carrier
22	(3) Gear Mount
---	Inspection Plate
100	* Spiral Bevel Gear Set
200G	Helical Gear
200P	Helical Pinion Gear
300	Oil Pump
303	Oil Pump Drive Plate
400	Output Shaft - Untapered
450	Above Gear Spacer (Interm. Shaft)
451	Between Gear Spacer (Interm. Shaft)
452	Below Gear Spacer (Output Shaft)
453	Below Gear Spacer (Interm. Shaft)
500	(4) Horizontal Shaft
550	(4) Horz. Spacer - Inner
560	Horizontal Locknut Set
561	(4) Horizontal Gear Retainer
570	Oil Slinger Plate
600	* Upper Bearing Output Shaft
601	* Lower Bearing Output Shaft
602	* Outer Bearing Horiz. Shaft
603	* Inner Bearing Horizontal Shaft
604	* Upper Bearing Interm. Shaft
605	* Lower Bearing Interm. Shaft
802	* Horiz. Seal Set
815	* Vertical Seal Set
823	Breather Plug
824	* Bearing Shims (Output Shaft)
826	* Bearing Shims (Interm. Shaft)
828	O-Ring
829	O-Ring
836	Horizontal Carrier Oil Ring
910	Gear Key Interm. Shaft
911	Gear Key Horiz. Shaft
912	Gear Key Output Shaft
913	(4) Oil Slinger Key
---	Oil Sight Glass
914	Cooling Fan

* Recommended Spares

PART NUMBER					
Global G80	Global G100	Global G110	Global G120	Global G125	Global G130
D1-11	D2-11	D3-11	D4-11	D4-11	D5-11
D1-15	D2-15	D3-15	D4-15	D5-15	D5-15
F4-16A	F4-16A	D3-16A	D3-16A	D5-16A	D5-16A
D1-17AM	D2-17AM	D2-17AM	D4-17AM	D4-17AM	D5-17AM
D1-17BM	D2-17BM	D3-17BM	D4-17BM	D4-17BM	D5-17BM
17M-G80	17M-G100	17M-G110	17M-G120	17M-G125	17M-G130
D1-18	D2-18	D2-18	D4-18	D4-18	D4-18
D1-19	D2-19	D3-19	D4-19M	D4-19M	D5-19
D1-20	D2-20A	33018	D4-20	D4-20	D4-20
D1-21	D2-21	D3-21	D4-21	D4-21	D5-21
----	----	D3-22	D4-22	D4-22	D4-22
L18B	L18B	L18B	L18B	L18B	L18B
SEE NOTE #2	SEE NOTE #2	SEE NOTE #2	SEE NOTE #2	SEE NOTE #2	SEE NOTE #2
200G-G80	200G-G100	200G-G110	200G-G120	200G-G125	200G-G130
200P-G80	200P-G100	200P-G110	200P-G120	200P-G125	200P-G130
300-G80	300-G100	300-G110	300-G120	300-G125	300-G130
303-G80	303-G100	303-G110	303-G120	303-G125	303-G130
32028	32028	32028	34028	34203	35028
450-G80	450-G100	450-G110	450-G120	450-G125	450-G130
451-G80	451-G100	451-G110	451-G120	451-G125	451-G130
452-G80	452-G100	452-G110	452-G120	452-G125	452-G130
453-G80	453-G100	453-G110	453-G120	453-G125	453-G130
500-G80	500-G100	500-G110	500-G120	500-G125	500-G130
----	----	550-G110	550-G120	550-G125	550-G130
3268	3268	5237	5237	6217	6217
N/W-09	N/W-09	N/W-08	N/W-10	N/W-10	N/W-10
31027	32025	32025	34022	34022	34022
600-G80	600-G100	600-G110	600-G120	600-G125	600-G130
601-G80	601-G100	601-G110	601-G120	601-G125	601-G130
602-G80	602-G100	602-G110	602-G120	602-G125	602-G130
603-G80	603-G100	603-G110	603-G120	603-G125	603-G130
604-G80	604-G100	604-G110	604-G120	604-G125	604-G130
605-G80	605-G100	605-G110	605-G120	605-G125	605-G130
802-G80	802-G100	802-G110	802-G120	802-G125	802-G130
815-G80	815-G100	815-G110	815-G120	815-G125	815-G130
823	823	823	823	823	823
824-G80	824-G100	824-G110	824-G120	824-G125	824-G130
826-G80	826-G100	826-G110	826-G120	826-G125	826-G130
M AS255	M AS363	M AS364	M AS369	M AS369	M AS268V
M AS246	M AS251	M AS255	M AS258V	M AS258V	M AS362
----	----	34152	34152	35106	35106
910-G80	910-G100	910-G110	910-G120	910-G125	910-G130
911-G80	911-G100	911-G110	911-G120	911-G125	911-G130
912-G80	912-G100	912-G110	912-G120	912-G125	912-G130
913-G80	913-G100	913-G110	913-G120	913-G125	913-G130
P1030-4	P1022-6	P1022-6	P1022-6	P1022-6	P1022-6
FAN 16	FAN 16	FAN 20	FAN 20	FAN 22	FAN 22

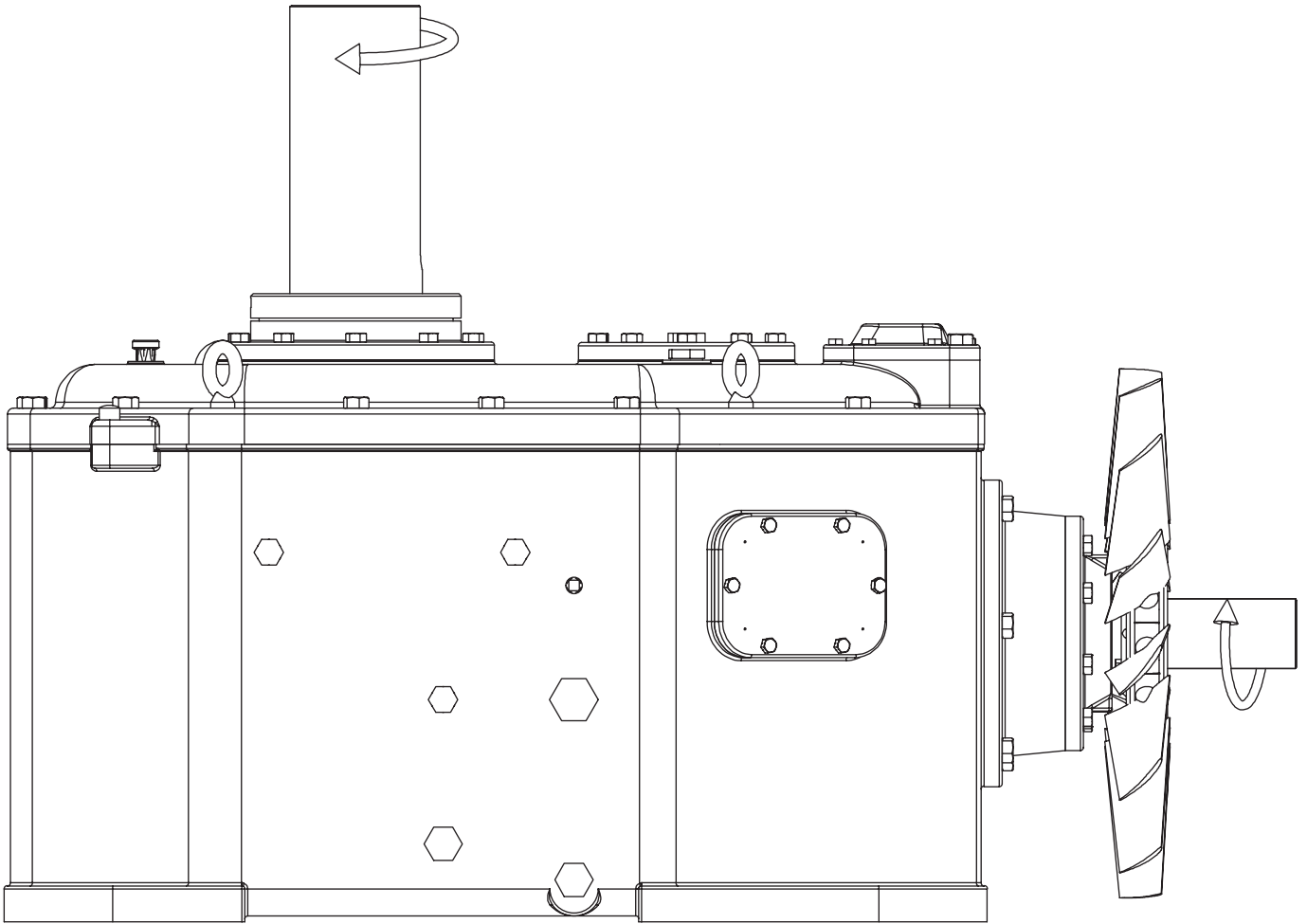

***RECOMMENDED MINERAL OILS**

AMBIENT TEMPERATURE AT GEAR DRIVE	20° F to 120° F (-7° C to 49° C)
AGMA LUBRICANT NUMBER	6
ISO Grade	320
Atlantic Richfield Co. Chevron Oil Co. Cities Service Oil Co. Conoco Exxon Company Gulf Oil Corp. Mobil Oil Corp. Pennzoil Phillips Petroleum Co. Shell Oil Co. Sun Oil Co. Texaco Inc. Total	Duro 320 Machine Oil A W 320 Citigo Pacemaker 320 Hydroclear Multipurpose R & O Oil 320 Teresstic 320 Harmony 320 Vacuoline 537 Pennzbell TO 320 Magnus 320 Morlina 320 Sunvis 9320 Regal R & O 320 Carter 320

*LIST OF BRAND NAMES IS FOR PURPOSE OF IDENTIFYING TYPES AND IS NOT TO BE CONSTRUED AS EXCLUSIVE RECOMMENDATIONS.

***RECOMMENDED SYNTHETIC LUBRICANTS**

AMBIENT TEMPERATURE AT GEAR DRIVE	-20° F to 150° F (-29° C to 66° C)
AGMA LUBRICANT NUMBER	6S
ISO GRADE	320
Chevron Oil Co. Conoco Mobil	Clarity 320 Synthetic Syncon 320 – R & O Oil SHC 632

LUBRICATION: Use only Rust and Oxidation Inhibited Gear Oils in accordance with AGMA (American Gear Manufacturers Association), Standard 9005-F16 (or most recent edition of the standard). For general operating conditions, use a lubricant having an AGMA lubricant number of 6. Gear oils containing Extreme Pressure (EP) additives are not recommended, and should never be used on gear drives equipped with the nonreverse option.

If the gear drive is started when the ambient temperature is below 20° F (-7° C), use a lube oil heater or a recommended synthetic oil. Lube oil heaters and synthetic oil are extra cost accessories that can be ordered with new gear drives or installed in the field.

SYNTHETIC LUBRICANTS: Synthetic lubricants offer advantages of extended service life, a broader operational temperature range, reduced friction, and the ability to maintain a higher film strength which can extend the service life of the gear drive. When the operating temperature exceeds 180° F (82° C) or the gear drive is started when the ambient temperature is below 20° F (-7° C), a synthetic lubricant is recommended. Synthetic lubricants can be made of various base stocks which are incompatible with certain gear drive components; therefore, any synthetic lubricant not listed in this bulletin should be approved by Amarillo Gear Company. Do not use synthetic lubricants made from ester base stocks. Change intervals for synthetic lubricants should not be extended beyond the change interval for mineral oils without a comprehensive monitoring program.

CHANGE INTERVAL: The original oil should be replaced after 500 hours of operation or four weeks, whichever comes first. It is recommended that the oil be drained when it is at or near operating temperature. Refill the drive with the recommended type and amount of lubricant. The amounts below are recommendations and your specific gear box refill amount will vary depending on options and any residual oil left in the gear box. It is important that the gear box be filled to the center of the gear box sight glass for proper lubrication.

Per AGMA standards the oil should be changed every 2500 hours or every six months, whichever comes first. Shorter change intervals of two or three months may be required if the gear drive is subjected to unusual operating conditions such as rapid temperature changes, consistent high operating temperature or any conditions that tend to contaminate the oil or promote the formulation of sludge and deposits inside the gear case. If your cooling tower drive is equipped with an optional oil filter, the filter cartridge should be changed when the oil is replaced.

The vertical and horizontal shafts are equipped with grease lubricated dual seals. Relubrication is not required.

OIL CAPACITY

MODEL	GALLONS	LITERS
G80	6	23
G100	8.5	32
G110	14	53
G120	21	80
G125	22	83
G130	24	91